

JUMO GmbH & Co. KG
 Delivery address: Mackenrodtstraße 14,
 36039 Fulda, Germany
 Postal address: 36035 Fulda, Germany
 Phone: +49 661 6003-0
 Fax: +49 661 6003-607
 e-mail: mail@jumo.net
 Internet: www.jumo.net

JUMO Instrument Co. Ltd.
 JUMO House
 Temple Bank, Riverway
 Harlow, Essex CM 20 2TT, UK
 Phone: +44 1279 635533
 Fax: +44 1279 635262
 e-mail: sales@jumo.co.uk
 Internet: www.jumo.co.uk

JUMO Process Control, Inc.
 8 Technology Boulevard
 Canastota, NY 13031, USA
 Phone: 315-697-JUMO
 1-800-554-JUMO
 Fax: 315-697-5867
 e-mail: info@jumo.us
 Internet: www.jumo.us



Differential Pressure Transmitter

JUMO MIDAS DP10

Type 401050

Brief description

This differential pressure transmitter measures the pressure in liquid and gaseous media. The difference between the two pressures is converted into an analog output signal. The piezo-resistive silicon sensor is built into a stainless steel housing.

Technical data

Unless further specified, all the following percentage values refer to the measurement span.

Reference conditions

as per DIN 16 086 and EN 60 770

Measuring ranges

Meas. range	Max. system pressure ²	Max. overload on both sides ²	Max. single-sided overload		Bursting pressure	Overall error ³ (% of full scale)	Long-term stability (per annum)
			+ side	- side			
0 to +0.4 bar	5 bar	7.5 bar	7.5 bar	5 bar	≥ 60 bar	≤ 2.5% ⁴	≤ 0.6%
0 to +0.6 bar						≤ 2.5% ⁴	
0 to +1 bar						≤ 2.3% ⁴	
0 to +1.6 bar	10 bar	15 bar	15 bar	10 bar	≥ 60 bar	≤ 2.0% ⁴	≤ 0.6%
0 to +2.5 bar						≤ 2.0% ⁴	
0 to +4 bar	30 bar ¹	45 bar	15 bar	10 bar	≥ 60 bar	≤ 1.8% ⁴	≤ 0.4%
0 to +6 bar			25 bar			≤ 1.8% ⁴	
0 to +10 bar			30 bar			≤ 1.5% ⁴	
0 to +16 bar			30 bar			≤ 1.5% ⁴	



Type 401050/000-xxx-xxx-xxx-xx-xxx-61

Parts in contact with medium⁵

stainless steel, Mat. Ref. 1.4571
 stainless steel, Mat. Ref. 1.4435
 stainless steel, Mat. Ref. 1.4305
 plastic, PBT GF30 or
 plastic, POM GF40
 seal: FPM

Output

4 – 20 mA 2-wire
 burden ≤ (U_B-10 V) / 0.02A
 0.5 – 4.5 V ratiometric
 burden ≥ 20 kΩ

Burden error

< 0.5%

Zero offset

≤ 0.3%

Thermal hysteresis

(within the compensated range -15 to +85°C)
 for meas. ranges ≤ 0.6 bar: ≤ ± 1%
 for meas. ranges > 0.6 bar: ≤ ± 0.5%

Step response

for current output ≤ 3 msec
 for voltage output ≤ 10 msec

Supply voltage

10 – 30 V DC (for 4 – 20 mA output)
 5 V DC ± 0.5 V (for 0.5 – 4.5 V output)
 Ripple: the voltage peaks must not go outside the limits specified for the supply.
 Max. current drawn: 25 mA

Supply voltage error

≤ 0.02% per V for 4 – 20 mA output

Nominal supply voltage

24 V DC
 ratiometric for 0.5 – 4.5 V output

Operating temperature

ambient: -20 to +80°C
 medium: -15 to +100°C⁶
 storage: -50 to +100°C

Electromagnetic compatibility (EMC)

as per EN 61 326
 interference emission: Class B
 interference immunity: to industrial requirements

¹ Maximum ambient temperature +60°C

² For simultaneous pressure on both + and - sides

³ The total error includes errors due to linearity, hysteresis, reproducibility and temperature drift over the range from -15 to +85°C.

⁴ of full scale

⁵ The customer must test the compatibility with the medium being measured.

⁶ If the medium is water at temperatures above 50°C, then pipes or hoses must be used to separate the transmitter from the process. E. g. for water at 85°C, at least 200 mm long (depending on the ambient temperature).

® Bayer Material Science

JUMO GmbH & Co. KG
 Delivery address: Mackenrodtstraße 14,
 36039 Fulda, Germany
 Postal address: 36035 Fulda, Germany
 Phone: +49 661 6003-0
 Fax: +49 661 6003-607
 e-mail: mail@jumo.net
 Internet: www.jumo.net

JUMO Instrument Co. Ltd.
 JUMO House
 Temple Bank, Riverway
 Harlow, Essex CM 20 2TT, UK
 Phone: +44 1279 635533
 Fax: +44 1279 635262
 e-mail: sales@jumo.co.uk
 Internet: www.jumo.co.uk

JUMO Process Control, Inc.
 8 Technology Boulevard
 Canastota, NY 13031, USA
 Phone: 315-697-JUMO
 1-800-554-JUMO
 Fax: 315-697-5867
 e-mail: info@jumo.us
 Internet: www.jumo.us



Mechanical shock

(to IEC 68-2-27)
 100 g/1msec

Mechanical vibration

(to IEC 68-2-6)
 ≤ 20 g for 15 – 2000 Hz

Enclosure protection

(to EN 60 529)
 with round connector M12 x 1: IP67
 with bayonet to DIN 72585: IP67
 with fixed cable: IP67

Process connection

2 x G1/8 internal thread
 adapters for pipes and hoses: see order details

Electrical connection

see order details

round connector M12 x 1
 or
 bayonet connector DIN 72585
 or
 fixed cable, 2 m (other lengths on request)

Operating position

unrestricted
 (deviations from the nominal operating position can cause an error of up to 2 mbar)

Weight

180 g
 (approx. 220 g with mounting bracket)

Fixing options

- 3 holes on housing bottom
- mounting bracket (accessory)
- on measurement lines (e.g. 6 x 1 pipe)

Nominal position

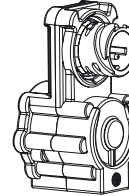

Electrical connection

		 Bayonet connector	 Round connector	Cable
Voltage output				
Supply voltage		1 L+		white L+
11.5 – 30 V DC ±0.5 V (with output 0 to 10 V)		2 L-		brown L-
5 V DC ±0.5 V (with output 0.5 to 4.5 V)				
Output		2 -		brown -
0 – 10 V		3 +		black +
0.5 – 4.5 V				
Current output				
Supply voltage			1 +	white L+
10 – 30 V DC			3 -	brown L-
Output			1 +	white L+
4 – 20 mA (2-wire)			3 -	brown L-

Dimensions

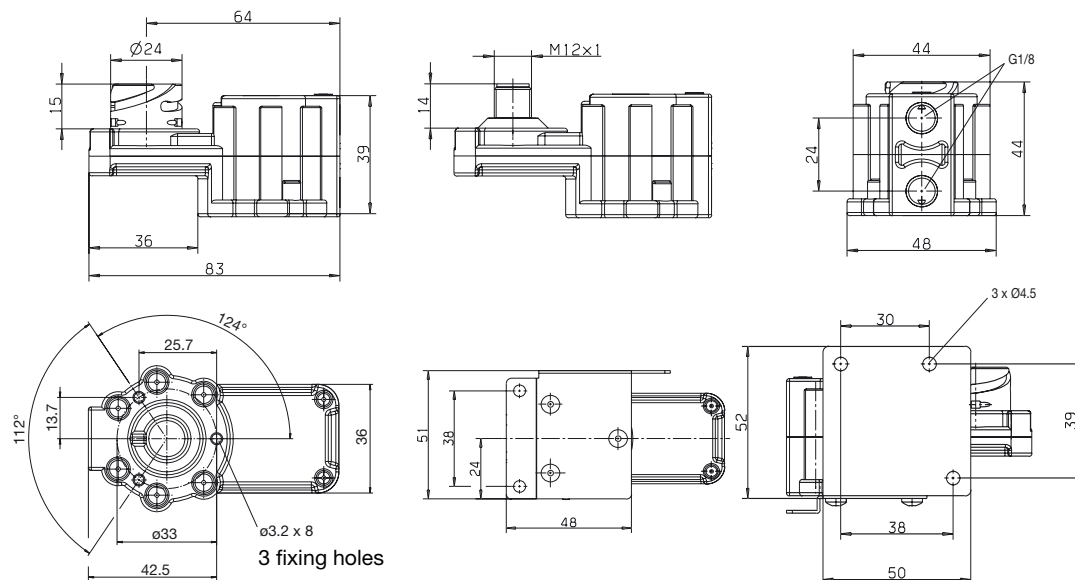

JUMO GmbH & Co. KG
 Delivery address: Mackenrodtstraße 14,
 36039 Fulda, Germany
 Postal address: 36035 Fulda, Germany
 Phone: +49 661 6003-0
 Fax: +49 661 6003-607
 e-mail: mail@jumo.net
 Internet: www.jumo.net

JUMO Instrument Co. Ltd.
 JUMO House
 Temple Bank, Riverway
 Harlow, Essex CM 20 2TT, UK
 Phone: +44 1279 635533
 Fax: +44 1279 635262
 e-mail: sales@jumo.co.uk
 Internet: www.jumo.co.uk

JUMO Process Control, Inc.
 8 Technology Boulevard
 Canastota, NY 13031, USA
 Phone: 315-697-JUMO
 1-800-554-JUMO
 Fax: 315-697-5867
 e-mail: info@jumo.us
 Internet: www.jumo.us



Order details

- 401050 (1) **Basic type** Differential pressure transmitter JUMO MIDAS DP 10
- /000 (2) **Basic type extensions** none
- /999 special version
- 452 (3) **Input for differential pressure** 0 – 0.4 bar
- 453 0 – 0.6 bar
- 454 0 – 1.0 bar
- 455 0 – 1.6 bar
- 456 0 – 2.5 bar
- 457 0 – 4 bar
- 458 0 – 6 bar
- 459 0 – 10 bar
- 460 0 – 16 bar
- 999 special measuring range
- 405 (4) **Output** 4 – 20 mA 2-wire
- 412 0.5 – 4.5 V 3-wire
- 415 0 – 10 V 3-wire
- 305 (5) **Process connection¹** screwed pipe joint, 6mm dia., stainless steel 1.4571 / FPM
- 306 screwed pipe joint, 6mm dia., brass
- 593 2 x G 1/8 to EN 837
- 68 (6) **Housing material** PBT
- 601 (7) **Seal material** FPM
- 11 (8) **Electrical connection** fixed cable, 2 m
- 36 round connector M 12 x 1
- 53 bayonet connector to DIN 72585
- 000 (9) **Extra codes** none

	(1)	(2)	(3)	(4)	(5)	(6)	(7)	(8)	(8)
Order code									
Order example	401050	/ 000	- 454	- 405	- 593	- 68	- 601	- 36	/ 000

Accessories

Designation

- screwed pipe joint, 6mm dia., stainless steel 1.4571
- screwed pipe joint, 6mm dia., brass
- Mounting bracket and Screws for mounting the differential pressure transmitter
- 4-pole straight connector M12 x 1 with 2m PVC cable
- 4-pole angled connector M12x1 with 2m PVC cable

Sales No.

- 40/
- 40/
- 40/00448193
- 40/00404585
- 40/00409334

¹ other process connections on request.