

TYPE 502

Type 502 is a heavy duty, tapered drilled, bar stock thermowell that protects heavy industrial application sensors from corrosion, high pressure and high velocity elements.

Type 502 is available with a variety of features and options to meet users' specific requirements, including:

- Immersion Length
- Process Connection
- Sensor Connection
- Overall Length
- Well Material

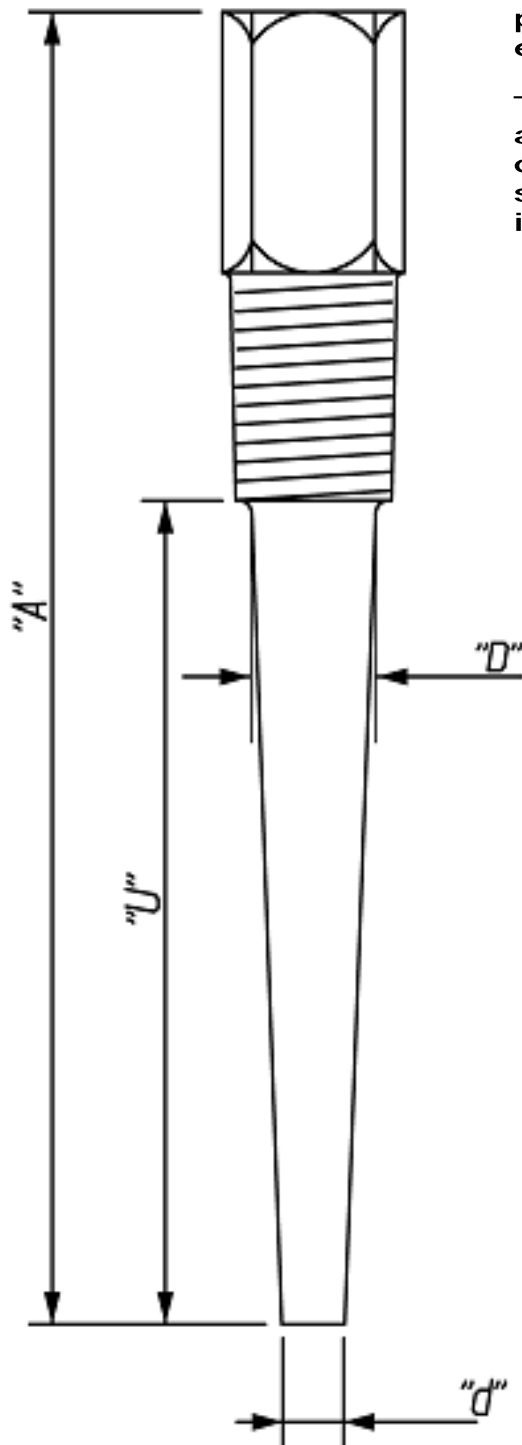

Michshur S.Z. (1984) Ltd.
8 Hagavtsh St.
P.O.B. 1951 Holon 5881614
ISRAEL
Phone: 972-3-6508585 Fax: 972-3-6508586

HOW TO ORDER

TABLE NO

1

2

3

4

5

EXAMPLE

ORDER NO 502

0150

M

1M

0250

8

Example Order No. = Type 502 tapered drilled bar stock thermowell ; 150 mm length ; 1/2" NPT process connection ; 1/2" NPT sensor connection ; 250 mm total overall length ; 316 ST.ST.

Table 1. Dimension "U"

Insert "U" in mm.
(4 digits)

Table 2. Process Connection

Order	Diameter
M	1/2" N.P.T
R	1/2" B.S.P
Q	3/4" N.P.T
V	3/4" B.S.P
O	Other

Table 3. Sensor Connection

Order	Description
1M	1/2" N.P.T
1R	1/2" B.S.P
1O	Other

Table 4. Dimension "A"

Insert "A" in mm.
(4 digits)

Table 5. Well Material

Order	Description
4	310 ST.ST
8	316 ST.ST
9	304 ST.ST
10	Other

NOTES :

- "D" and "d" are proportional to the process connection :
For 1/2" D=18 mm d=15 mm.
3/4" D=23 mm d=18 mm.
1" D=29 mm d=18 mm.
- Standard Length, "A" = "U" + 44mm.
- For extension type, "A" = "U" + "T" + 44 mm.